

A SMART STICK FOR ASSISTING VISUALLY IMPAIRED PEOPLE

¹ASHRAF ANWAR, ²SULTAN ALJAHDALI

¹Assoc Prof., Department of Computer Engineering, College of Computers and Information Technology,
Taif University

² Prof., Department of Computer Science, College of Computers and
Information Technology, Taif University

E-mail: ¹ashraaf@tu.edu.sa, ²aljahdali@tu.edu.sa

ABSTRACT

This paper presents a smart stick system for assisting blind or visually impaired people. The smart stick acts as a vision assistant to enable visually impaired people to find difficulties in obstacles detection and dangers in front of them for autonomous navigation. Unlike existing papers, related to obstacles detection means: ultrasonic sensor, infrared sensor, and water sensor, alarm modules: buzzer, sound, and voice statement, and a location finder like the GPS/GSM system, the proposed system integrates all these technologies for the benefits of the blind. The system is designed to act like an artificial vision associated with an alarm unit, and a location finder of the blind. The Global Positioning System (GPS) and Global System for Mobile communications (GSM) are interfaced to the microcontroller to detect the blind person location. The feedback from the real test was positive. The average of avoidance accuracy is 88.75%.

Keywords: *Obstacle Detection, Ultrasonic Sensor, Infrared Sensor, Microcontroller, GPS.*

1. INTRODUCTION

According to World Health Organization report, there are approximately 285 million persons around the world who are visually impaired, out of which 39 million are completely blind [1]. Visually impaired persons have difficulty to interact and feel their environment. Physical movement is a challenge for visually impaired persons, because it can become tricky to distinguish where he is, and how to get where he wants to go from one place to another. To navigate unknown places, he will bring a sighted family member or his friend for support. Over half of the legally blind people in the world are unemployed because of the limited types of jobs they can do. They are relying on their families for mobility and financial support. Their mobility opposes them from interacting with people and social activities.

Electronic Travel Aids (ETAs) devices have been introduced recently to be a mobility aid for the blind people to help the blind to move freely in an

environment regardless of its dynamic change. These devices rely on signal processing and sensor technology. Some of these devices are used to guide the blind via detecting land-marking like near-infrared (IR) light or radio frequencies [2-3]. Alternatively, instead of guiding his path, devices might protect him hitting obstacles. These devices are either sensor based or vision based.

In sensor based, ultrasonic or laser devices are used. N. Mahmud, et al. [4], proposed a vibration and voice operated navigation system to guide a visually impaired person safely through the use of 3 ultrasonic sensors to determine range of obstacles from forward, left, and right.

Amjed, et al. [5] proposed a smart system of 3 ultrasonic sensors to determine the range of obstacles from an infrared microcontroller-based blind guidance system to improve the mobility of blind people in a specific area. Through the use of 3 IR sensors, information about the object characteristics are obtained.

. Bhatlawande, et al. [6] proposed ultrasonic

spectacles and waist-belt for blind person, the system understands obstacles around the subject up to 500 cm in front, left and right directions using a network of ultrasonic sensors.

Other sensor based systems include UltraCane [7], Survey [8], Palmsonar [9], Ultra-Body-Guard [10], iSonic cane [11], Laser Cane [12], and Teletact [13]. In such systems, the devices receive reflected waves and produce audio buzzer, sounds, voice statements, or vibration in response to detected obstacles, others [14-19].

Vision based systems use digital video cameras as vision sensor like Meijer [20], G. Sainarayanan, et al. [21], AudioMan [22], and SoundView [23]. These systems use single camera or stereo video cameras mounted on a wearable device to capture images. These captured images are processed and converted to speech, audio, musical sounds or vibrations. In such systems, the frequency of warning sound signal is correlated with the orientation of pixels. Some advanced systems use Global Positioning System (GPS) integrated with the main system. GPS receiver is useful for determining the current location of the subject [24-27].

Existing paper works and solutions related to obstacle detection techniques, audio warning modules, GPS/GSM system, reveal that, so far, all these technologies have been implemented individually but not integrated for the benefit of the blind.

In our work, we intend to integrate all the essential components in a single system to provide a one stop solution to all the facilities a blind person may require for easy navigation and usability. The system to be designed has the following advantages:

- It incorporates all sensor types in one detection unit against all possible obstacles and dangers.
- It enables the user to sense the size of the obstacles, various voice announcements corresponding to type of input will be given as output.
- LDR sensor alerts people about the presence of the blind person.
- In case of emergency, the user can press the alert button, where his current location, received from the GPS system, will be sent to his friend via SMS.
- The system uses Light weight components integrated to the stick.
- It is low cost, wearable, and easy to use without training.

The paper is organized as follows: Section 2 represents the proposed system. Results and Discussion are presented in section 3. Finally, section 4 concludes this paper.

2. THE PROPOSED SYSTEM

The block diagram of the proposed system, as shown in figure 1, is composed of the following units:

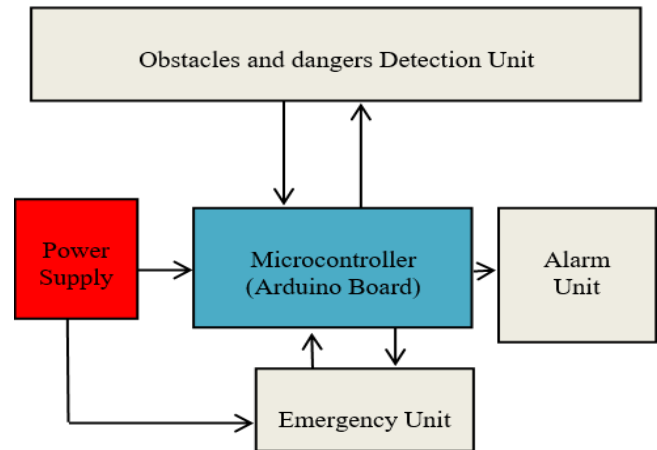

Figure 1: The Block Diagram of the Proposed System.

2.1 Microcontroller:

Arduino Uno R3 is used in the stick as the main control unit as shown in figure 2. This ATmega328 based controller is very sophisticated and widely adopted in various embedded applications. It has 16 MHz crystal oscillator, 14 digital I/O pins in which 6 can be used as PWM, 6 analog pins, 2 KB SRAM, 1 KB EEPROM, 32 KB Flash memory, power jack, USB connection and other usually required features. It contains almost everything needed to support a microcontroller and it can be powered by any 7-12V battery or AC-to-DC adapter.

It can be programmed easily and the actuators can be governed based on the sensor's input and the program.

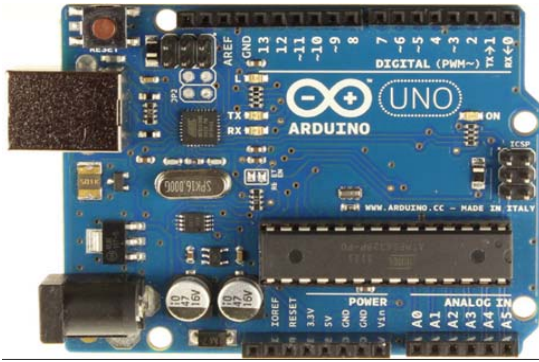

Figure 2: Arduino Uno R3 Microcontroller

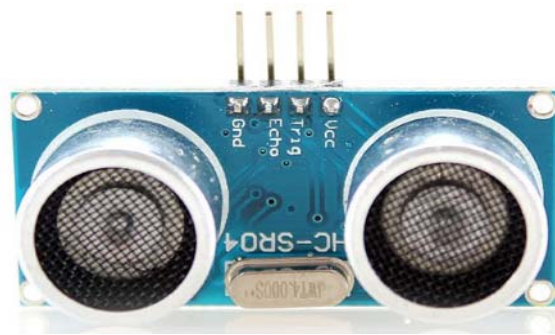

Figure 3: Ultra-sonic HC-SR04

2.2 Obstacles and Dangers Detection Unit.

This unit consists of three types of sensors:

2.2.1 Ultrasonic sensor.

2.2.1.1 Ultrasonic basics.

Ultrasound is far above the range of human hearing, which is only about 20 Hz to 20 KHz. The sound of frequency above 20 KHz is called ultrasonic sound. Modern ultrasonic generators can produce frequencies up to about 10 GHz. Higher frequencies have shorter wavelengths, which allow them to reflect from objects and to provide better information about those objects. However, extremely high frequencies are difficult to generate and to measure.

Ultrasonic sensors depend on two separate devices: an ultrasonic transducer and a detector. An ultrasonic transducer is any device that converts energy into an ultrasonic frequency. They are usually made from piezoelectric crystals that can change size when a voltage is applied to them. When an alternating current is applied to a piezoelectric crystal, it vibrates extremely fast and produces an ultrasonic sound wave. The detector is also made of a piezoelectric crystal, but produces a voltage when an ultrasonic frequency comes in contact with it, effectively producing the opposite results. A sensor calculates the time it takes in between broadcasting the ultrasonic frequency and receiving the incoming waves. Ultrasonic is used in a variety of applications such as, sonic rulers, proximity detector, movement detectors, liquid level measurement, robotics, security devices, laboratory, and a host of other applications.

2.2.1.2 Ultrasonic sensor (HC-SR04)

It uses sonar to compute the distance of any obstacle in its range. The ultra-sonic type HC-SR04 is shown in the figure 3.

Features:

- Ultrasonic ranging module HC - SR04 provides 2cm - 400cm distance range, with an effectual angle of 15 degree.
- The ranging accuracy can reach to 3mm.
- The module includes ultrasonic transmitter, receiver and control circuit.

Detection using ultrasonic sensor is based on the time of flight (TOF), the amount of delay between the emission of a sound and the arrival of an echo which is directly proportional to the distance (D)

$$D = \text{TOF}/2 \times V \quad (1)$$

V: velocity of sound (340 m/s)

Two ultrasonic sensors are used, an upper one at a 90-cm height to detect the upper obstacles and another sensor at a 30-cm height to detect low obstacles. After detecting the obstacles on the ground, ultrasonic sensor will send the signal to the Arduino and obstacle distance is calculated, as result a voice instruction for obstacle available at a specified distance is produced.

2.2.2 Infrared sensor.

2.2.2.1 Inferred basics

In the electromagnetic spectrum, the infrared portion is divided into three regions: near infrared region, mid infrared region and far infrared region. The wavelengths of these regions and their applications are shown below.

- Near infrared region: 700 nm to 1400 nm , IR sensors, fiber optic
- Mid infrared region: 1400 nm to 3000 nm, Heat sensing.
- Far infrared region: 3000 nm to 1 mm , Thermal imaging

The frequency range of infrared is higher than microwave and lesser than visible light. The wavelength of infrared waves falls between 700 nm

to 1 mm. This corresponds to 430 THz to 300 GHz respectively in the electromagnetic spectrum.

Infrared sensors are devices which emit and detect the Infrared waves as required in order to detect the distant object.

Infrared sensor includes a transmitter and a receiver, The IR transmitter is an IR LED (Light Emitting Diode) and the receiver is an IR photodiode which is sensitive to IR light of the same wavelength as that emitted by the IR LED.

When IR light falls on the photodiode, its resistance and correspondingly its output voltage change in proportion to the magnitude of the IR light received. This is the principle of working of Infrared sensors, shown in the figure 4. It can detect obstacles in a range within 20 cm at an angle of +/- 45 degrees accurately.

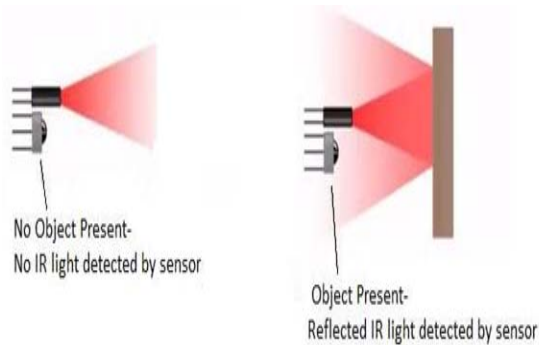

Figure 4: Infrared sensor working

This feature enables the user to identify any kind of stairs in front of him, as it located at the lower side of the stick.

2.2.2.2 Infrared sensor arduino.

IR sensor type GP2Y0A02YK0F chosen, is shown in the figure 5, has a detection range distance that goes from 20 to 150 cm, and an analog output corresponding voltage that goes from 2.8 to



Figure 5: GP2Y0A02YK0F Infrared Sensor

0.4 V respectively. IR sensor is used to detect small obstacles like pit, staircase, stone, or upward and downward stair.

Sharp GP2Y0A02YK0F IR Distance Sensor (20-150 cm) is included in Arduino Library and the measured distance is easily obtained. After detecting the obstacles distances on ground, IR sensor will send the signal to the Arduino, as result it will send a voice instruction for a small obstacle available. IR sensor connection to Arduino is shown in the figure 6.

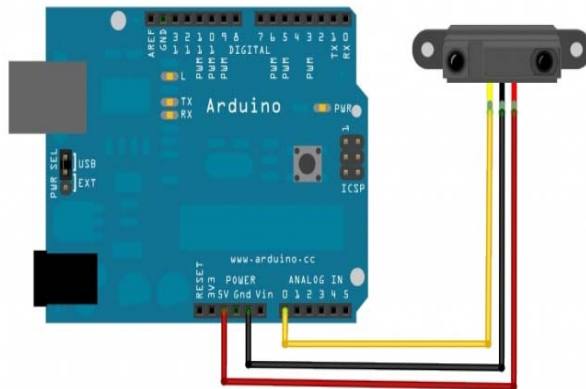

Figure 6: IR Sensor Connection To Arduino

2.2.3 Water sensor.

2.2.3.1 Water sensor basics.

A water sensor is a device used in the detection of the water level for various applications. Water sensors are of several types that include ultrasonic sensors, pressure transducers, bubblers, and float sensors. Ultrasonic sensors operate by transmitting sound waves that reflect from the liquid surface and are obtained by the sensor. The sensor measures the time interval between the transmitted and received signals, which is then converted into distance measurement with the help of electronic circuits within the sensor thereby measuring the level of the liquid

Float sensors work based on the change in resistance of a potentiometer within the sensor by the turning of a pulley or a spring-loaded shaft.

Bubbler sensors, on the other hand, measure water level by detecting the pressure of air-filled tubes with an open, submerged bottom end. The static pressure at the end of the tubes is more when the water level is high, and therefore more air pressure is required to fill the tube [28]

2.2.2.1 Arduino liquid level detection

Water Sensor is an easy to use, compact and light weight with the following features:

- Judge the water level through with a series of exposed parallel wires stitch to measure the water droplet/water size.
- Can easily change the water size to analog signal, and output analog value can directly be used in the program function, then to achieve the function of water level alarm.
- Low power consumption, and high sensitivity, which are the biggest characteristics of this module.

This sensor works by having a series of exposed traces connected to ground and interlaced between the grounded traces are the sense traces. The sensor traces have a weak pull-up resistor of 1 M Ω . The

resistor will pull the sensor trace value high until a drop of water shorts the sensor trace to the grounded trace. This circuit will work with the digital I/O pins of the Arduino or it can be used with the analog pins to detect the amount of water induced contact between the grounded and sensor traces [29].

It is located at the base of the stick as a precaution against the wet surface which can cause slipping on the floor and thus can hurt. When the water sensor comes in contact with the wet surface, it produces an electrical signal which triggers the Arduino controller. A voice instruction for wet surface is produced for alarming against a wet floor. Water sensor connection to Arduino is shown in the figure 7.

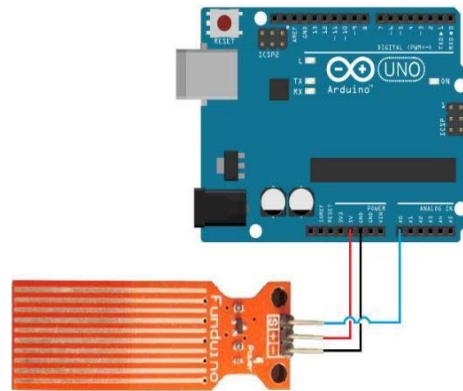

Figure 7: Water Sensor Connection To Arduino

The flow chart of the detection unit is shown in the figure 8.

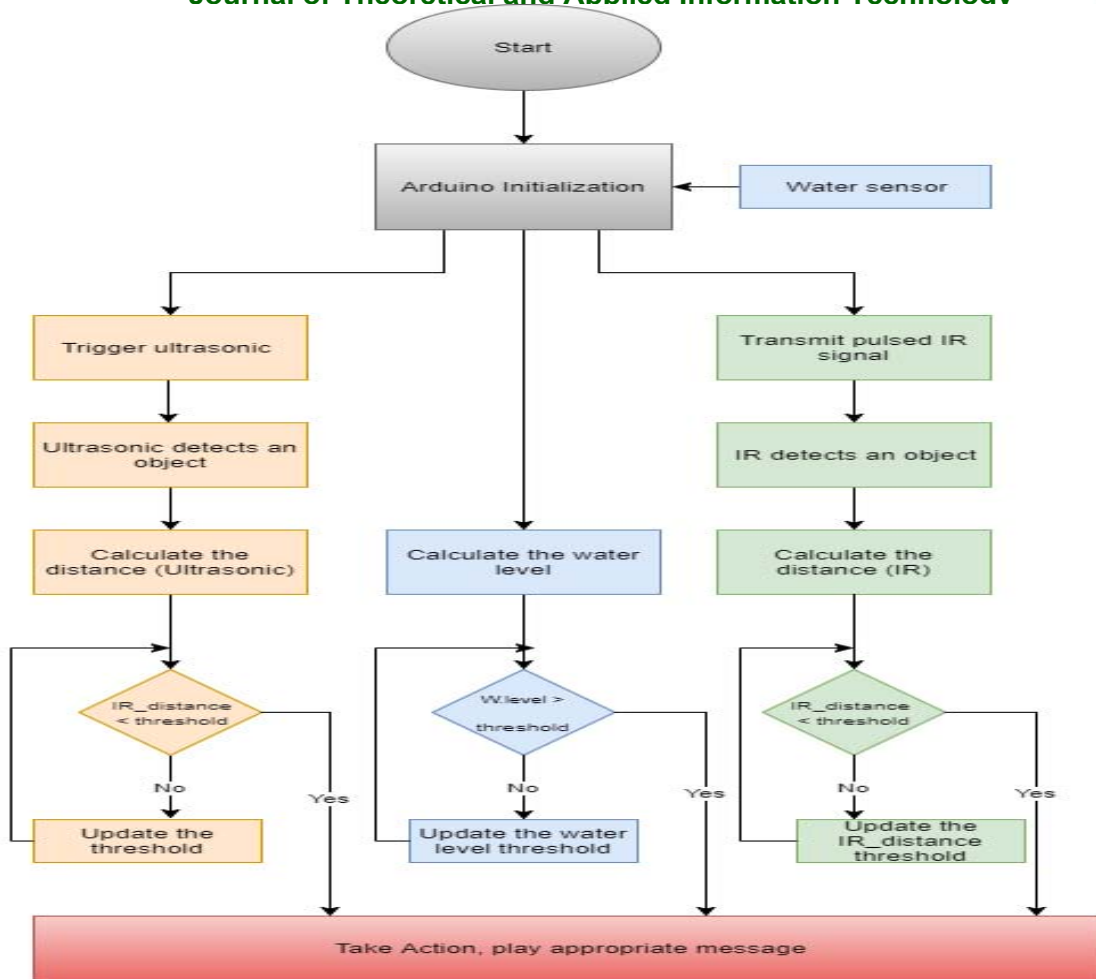

Figure 8: Flow Chart of the Detection Unit

2.3 Alarm Unit

The person is informed through a buzzer, vibrator motor, and a voice warning message. It consists of three parts:

2.3.1 Buzzer

A transducer (converts electrical energy into mechanical energy), that typically operates. A buzzer is in the lower portion of the audible frequency range of 20 Hz to 20 kHz. This is accomplished by converting an electric, oscillating signal in the audible range, into mechanical energy, in the form of audible waves. The buzzer is used in this research to warn the blind person against obstacle by generating sound proportional to distance from obstacle.

2.3.2 Vibration motor

This is a type of DC vibration motors used in mobile phones. This type of motors can be programmed to control its speed by using Pulse Width Modulation (PWM), the wider the pulse width, the more average voltage applied to the

motor terminals, the stronger the magnetic flux inside the armature windings and the faster the motor will rotate and this is shown in figure 9. A vibrator motor is included to enhance the overall feedback for the person who receives the warning against obstacles closeness in different formats of vibrations.

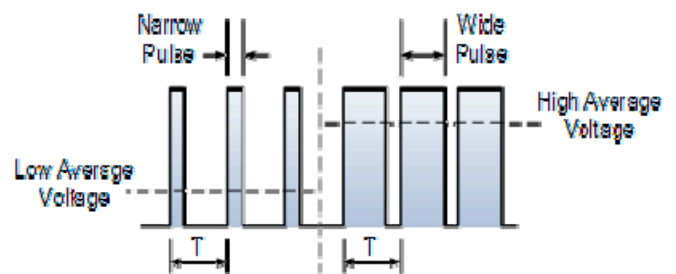

Figure 9: Pulse Width Modulated Waveform

2.3.3 Voice warning message

In addition to the vibrator motor and the buzzer, the proposed stick uses pre-recorded voice messages for conveying any detection of danger. It uses ISD1932 [30] circuit that contains a multiple-message recording and playback circuit. This circuit can record up to 64 seconds per message. It includes microphone inputs and speaker outputs. We can control the recording duration by adding an external resistor and a capacitor [14].

As shown in figure 10, the test circuit includes; an Arduino Uno, a 2” 8ohm speaker, a 4.7µF capacitor, a 100K resistor, wires, and a breadboard. Table 1 and Table 2 show scenario of the blind warning in nine states and speech warning messages in seven states respectively.

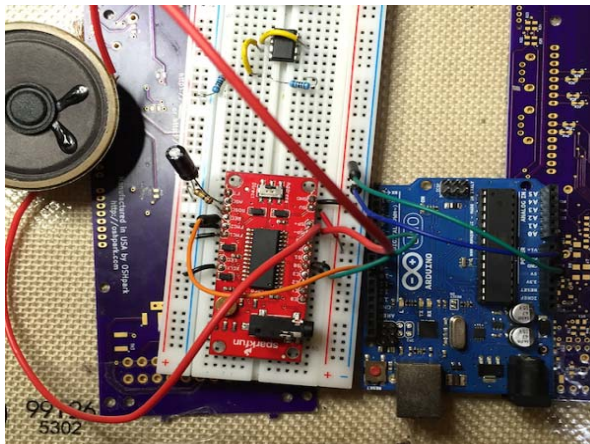

Figure 10: Arduino- ISD1932 Test Circuit

Table 1: Blind Warning Scenario

| Serial message | Speech warning message |
|----------------|--|
| Message 1 | Obstacle at 1.5 m approximately |
| Message 2 | Obstacle at 75 cm approximately |
| Message 3 | Danger, Obstacle less than 50 cm |
| Message 4 | Small obstacle, at 1.5 m approximately |
| Message 5 | Small obstacle, at 75 cm approximately |
| Message 6 | Danger, Small Obstacle less than 50 cm |
| Message 7 | Attention, there is water |

Table 2: Speech Warning Messages

| Sensor type | Threshold | Action | Message |
|-------------------|---------------|----------|-----------|
| Ultrasonic sensor | thr< 4m | Buzzer | - |
| | 2m< thr< 4m | Buzzer | - |
| | 1m< thr< 2m | V. Motor | Message 1 |
| | 0.5m< thr< 1m | V. Motor | Message 2 |
| | thr< 0.5m | V. Motor | Message 3 |
| IR sensor | 1m< thr< 2m | V. Motor | Message 4 |
| | 0.5m< thr< 1m | V. Motor | Message 5 |
| | thr< 0.5m | V. Motor | Message 6 |
| Water sensor | thr>0.1cm | V. Motor | Message 7 |

2.3.4 LDR sensor (Light Dependent Resistor)

This sensor changes its resistances due to change of the light intensity. During night, LDR will have high resistance and no current passes through it but through a LED connected parallel to it which illuminates and acts as a Flashlight. This light can be easily noticed by others. It alerts people about the presence of blind person to let him to free his way, LDR connection to Arduino is shown in the figure 11.

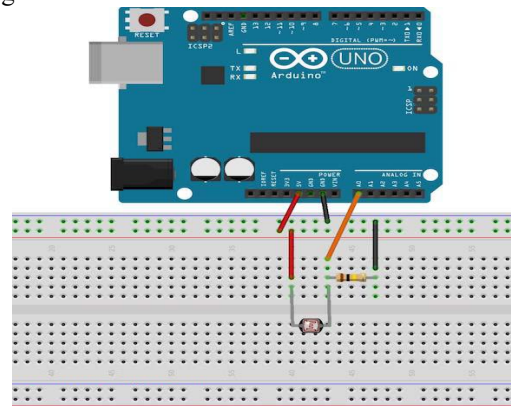

Figure 11: LDR Connection To Arduino

2.4 Emergency Unit.

2.4.1 Global positioning system.

The Global Positioning System (GPS) is a worldwide radio-navigation system formed from a constellation of 24 satellites and their ground stations.

GPS uses these "man-made stars" as reference points to calculate positions accurate to a matter of meters. In fact, with advanced forms of GPS you can make measurements to better than a centimeter.

In a sense it's like giving every square meter on the planet a unique address.

GPS receivers have been miniaturized to just a few integrated circuits and so are becoming very economical. That makes the technology accessible to virtually everyone.

These days GPS is finding its way into cars, boats, planes, construction equipment, movie making gear, farm machinery, even laptop computers.

GPS locates position based on triangulation:

- Position is calculated from distance measurements (ranges) to satellites.
- Mathematically we need four satellite ranges to determine exact position.
- Three ranges are enough to get exact location

The first and most obvious application of GPS is the simple determination of a "position" or location. GPS is the first positioning system to offer highly precise location data for any point on the planet, in any weather [31]

2.4.2 Global system for mobile communications (GSM)

It is a digital mobile communication system, and a consistent network. It comes up with a better and more efficient technical solution for wireless communication. Although GSM is based on the time division multiple access (TDMA) system, its technology uses digital signaling and speech channels and is considered a second generation (2G) mobile phone system.

GSM phones may be identified by the presence of a Subscriber Identity Module (SIM). This tiny object, which is about as wide as a finger, is a removable smart card that contains a user's subscription information, as well as some contact entries. Its end users were the first to take advantage of an inexpensive implementation of SMS (short message system), which is more popularly known as texting.

Being a cellular network, GSM makes use of cells to provide wireless communication to subscribers who are in the vicinity of these cells. The four main cells that make up a GSM network are called macro, micro, pico and femto. Outdoor coverage is typically provided by macro and micro cells, while indoor coverage is usually provided by the pico and femto cells [32].

The emergency unit consists of Global Positioning System (GPS) and Global System for Mobile communications (GSM) that are interfaced to the microcontroller to detect the blind person location. A GPS unit is used in the smart stick to obtain the latitude and longitude of the location of

the blind person. While the person navigates with the stick, the latitude and longitude data are updated. Thus, these data are helpful to keep track of the blind person. GSM module requires a registered SIM card to be inserted into it in order to operate. It facilitates making and receiving voice calls, sending SMS messages wirelessly.

Microcontroller get the location from the GPS modem and transmit the location to the GSM modem which will send a SMS messages to the all saved numbers. A visually impaired person during urgent or risky situations may use a switch on the stick that allows the GSM module to send an emergency message (which also specifies his location) to the concerned person, whose number has been saved already, requesting help.

3. RESULTS AND DISCUSSION

3.1 Sensors Test

Ultrasonic sensors, Infrared sensor, water sensor, and ISD1932 are tested individually with the Arduino, as well as integrated.

3.1.1 Ultrasonic sensor: It uses time of flight (TOF) to detect the obstacle at a certain distance from the obstacle. The output is a digital pulse which length is the time it takes for the sound to reach the target and return. We did several experiments on obstacles at different distances and the average TOF results are shown in the figure 12. The ultrasonic voltage is tested in the lab vs. distance and the recorded results are shown in the figure 13.

3.1.2 IR sensor:

It detects the obstacle based on the intensity of reflected wave from the obstacle surface and the distance of the obstacle from sensor varies according to value of reflected signal. Several experiments were done on obstacles at different distances and the results are shown in the figure 14

3.1.3 Water sensor;

To test the water sensor the sensor is placed in a glass. In order to test water level against output voltage of the water sensor, appropriate program is uploaded and ran the by the Arduino, the obtained results are shown in the figure 15

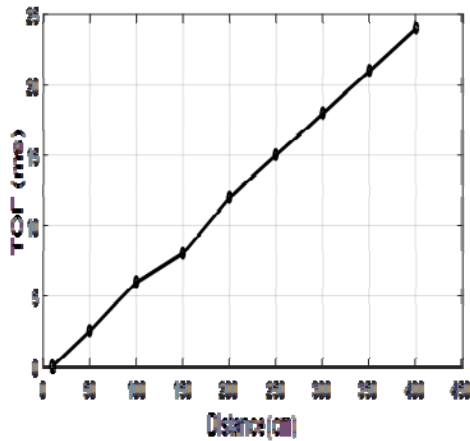

Figure 12: TOF vs. Distance in Ultrasonic Sensor

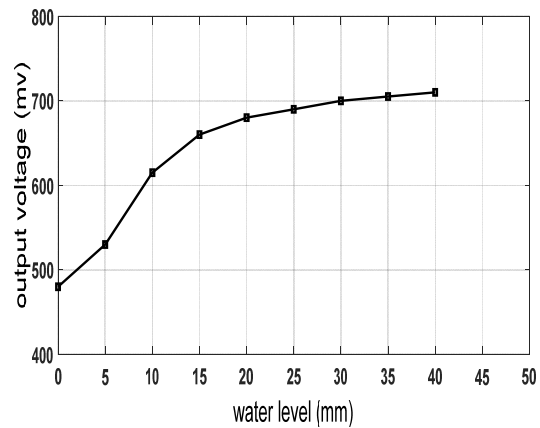

Figure 15: Water Sensor Output Voltage vs. Water Level

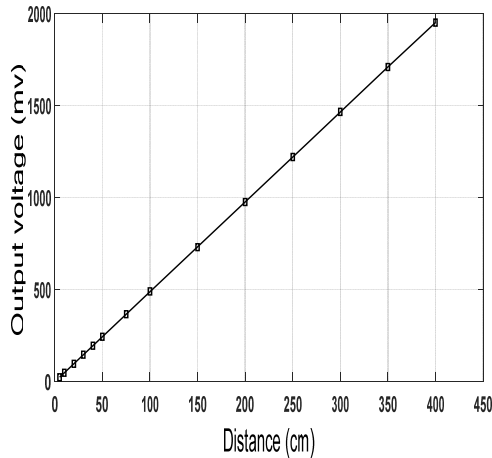

Figure 13: Ultrasonic Output Voltage vs. Distance

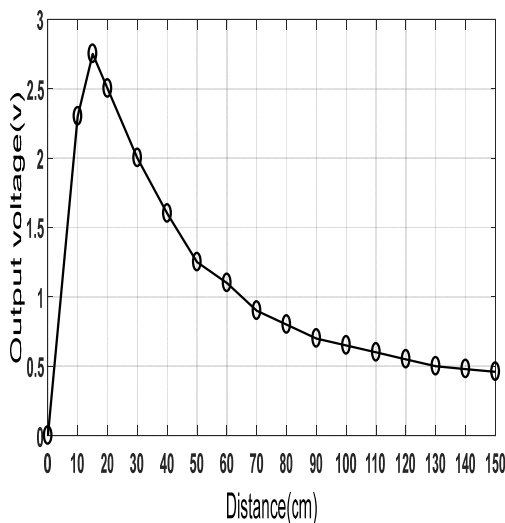

Figure 14: IR Sensor Output Voltage vs. Distance

3.2 Proposed System Test.

The proposed system is designed, implemented, and tested for practical use. The system is able to handle nine states that may face the blind person. The system will respond to each state according to a specific program which is Arduino coded. Real experiments were held by a group of four blind persons to detect the obstacles using the stick.

Nine obstacles of different sizes and distances according to the nine mentioned states were placed in their walking path. Most of obstacles were detected and the appropriate messages were heard by them. In some cases, they touched the obstacle, due to they were not taking enough space away from the obstacle, so these cases were considered as error.

The results of complete avoidance of hitting detected obstacles are shown in the figure 16.

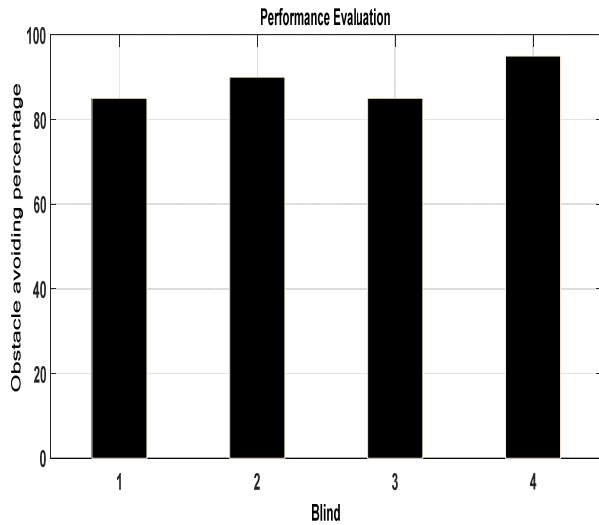

Figure 16: Obstacle Avoiding Percent vs. Blind Tester

3.3 Comparisons With Other Systems.

We compared the proposed system with last 3 years literature with 3 devices. Vibration and Voice Operated Navigation system for Visually Impaired Person [4], Assistive Infrared Sensor Based Smart Stick for Blind People [14], and An Intelligent sensor based stick for Blind and Deaf [19]. The comparison is shown in Table 3.

3.4 Arduino Vs Microcontroller

Arduino hides the complexity of Microcontrollers. Arduino has done every tedious task. In order to minimize the complexity, the Arduino provides an Integrated Development Environment (IDE) in which you can use to write the programs for Embedded Systems. Arduino is an open source platform introduced to make electronics prototyping easy by hiding the complexity of the embedded system through their Arduino IDEs and Arduino Boards.

Table 3: Comparisons With Other Systems

| System | Detection Range | Water Sensor | GPS/GSM | Micro-controller |
|-----------------|-----------------|--------------|---------|------------------|
| Proposed system | 4m | yes | yes | Arduino |
| System [4] | 2.9 m | No | No | PIC 16F877A |
| System [14] | 2m | No | No | PIC 16F877A |
| System [19] | 2m | No | yes | Arduino |

4. CONCLUSION

A smart stick system for assisting blind or visually impaired people is proposed in this paper. The proposed system is designed, implemented, and tested, making use of all available technologies, for the benefit of the blind person to navigate safely. Several sensors are used to detect all possible obstacles in his way, and warn him through appropriate messages.

The proposed system is integrated with the GPS/GSM system to locate the blind person and notify a dedicated person, whose phone number has been already saved, that the blind person is at risk.

The feedback from the real test was positive, all kind of obstacles and dangers are detected, and the blind person was alerted with an appropriate message. The average of avoidance accuracy was 88.75%.

REFERENCES:

- [1] World Health Organization, "Universal eye health: a global action plan 2014-2015.", 2014.
- [2] Peck, M. E. "RFID tags guide the blind". IEEE Spectrum, 1, 2008.
- [3] Saaid, M. F., Ismail, I., Noor, M. Z. H. "Radio frequency identification walking stick (RFIWS): A device for the blind". In Signal Processing & its Applications, 5th International Colloquium on IEEE, pp 250-253, 2009.
- [4] N.Mahmud, R.K.Saha, R.B. Zafar, M.B.H. Bhuiyan, and S.S.Sarwar, "Vibration and Voice Operated Navigation System for Visually Impaired Person," In Informatics, Electronics & Vision (ICIEV), International Conference on IEEE, pp. 1-5, 2014.
- [5] Amjed S. Al-Fahoum, Heba B. Al-Hmoud, and Ausaila A. Al-Fraihat, "A Smart Infrared Microcontroller-Based Blind Guidance System". Active and Passive Electronic Components, 2013.
- [6] Bhatlawande, Shripad S., Jayant Mukhopadhyay, and Manjunatha Mahadevappa. "Ultrasonic spectacles and waist-belt for visually impaired and blind person." Communications (NCC), National Conference on. IEEE, 2012.
- [7] B. Hoyle and D. Waters, "Mobility AT: The Batcane (UltraCane)," in Assistive Technology for Visually Impaired and Blind People, M. A. Hersh and M. A. Johnson, Springer London, pp. 209-229, 2008
- [8] Dakopoulos, D., & Bourbakis, N. G. "Wearable obstacle avoidance electronic travel aids for blind: a survey." Systems, Man, and Cybernetics, Part C: Applications and Reviews, IEEE Transactions on Vol. 40, pp. 25-35, 2010.
- [9] Fernandes, H., Costa, P., Paredes, H., Filipe, V. & Barroso, J. "Integrating Computer Vision Object Recognition with Location Based Services for the Blind," Universal Access in Human-Computer Interaction. Aging and Assistive Environments. Springer International Publishing, pp. 493-500, 2014.
- [10] Jameson, B., & Manduchi, R. "Watch your head: A wearable collision warning system for the blind," In Sensors, 2010 IEEE, pp. 1922-1927, 2010.
- [11] Kim, L., Park, S., Lee, S., & Ha, S. "An electronic traveler aid for the blind using multiple range sensors" IEICE Electronics Express Vol. 6, No. 11, pp. 794-799, 2009.
- [12] Benjamin, J. M., N. A. Ali, & A. F. Schepis. "A laser cane for the blind." Proceedings of the San Diego Biomedical Symposium. Vol. 12, pp. 53-57, 1973.
- [13] Johnson, L. A., & Higgins, C. M. "A navigation aid for the blind using tactile-visual sensory substitution," Engineering in Medicine and Biology Society, 2006. EMBS'06. 28th Annual International Conference of the IEEE, pp. 6289-6292, 2006.
- [14] Ayat A. Nada, M. A. Fakhr, Ahmed F. Seddik. "Assistive Infrared sensor based smart stick for blind people" Science and Information conference, London, UK, July 28-30, 2015.
- [15] J. M. Sáez, F. Escolano, and A. Peñalver, "First steps towards stereo- based 6DOF SLAM for the visually impaired," in IEEE Conf. on Computer Vision and Pattern Recognition (CVPR), San Diego, USA, 2005.
- [16] Alberto Rodriguez, et al., "Obstacle avoidance system for assisting visually impaired people", in proceeding IEEE Intelligent Vehicles Symposium Workshop, 2012.
- [17] Villanueva, J., & Farcy, R. "Optical device indicating a safe free path to blind people," Instrumentation and Measurement, IEEE Transactions on, Vol. 61, pp.170-177, 2012
- [18] Bouhamed, S. A., Eleuch, J. F., Kallel, I. K., & Masmoudi, D. S. "New electronic cane for visually impaired people for obstacle detection and recognition," Vehicular Electronics and Safety (ICVES), IEEE International Conference, pp. 416-420, 2012.
- [19] Gaurav Sareen, et al., "An intelligent sensor based stick for blind and deaf" Australian Journal of Basic and Applied Sciences, 11(8) special, pp. 34-38, 2017.
- [20] Meijer, P. B. "An experimental system for auditory image representations," Biomedical Engineering, IEEE Transactions on, vol. 39, no. 2, pp. 112-121, 1992.
- [21] G. Sainarayanan, R. Nagarajan, and S. Yaacob, "Fuzzy image processing scheme for autonomous navigation of human blind," Appl. Softw. Comput., vol. 7, no. 1, pp. 257-264, 2007.
- [22] Z.-G. Fang, J. Xu, F.-I. Bao, and L.-H. Zhang, "AudioMan: design and implementation of environmental information data mapping," Chinese Journal of Ergonomics, vol. 2, article 001, 2007.

- [23] M. Nie, J. Ren, Z. Li et al., "SoundView: an auditory guidance system based on environment understanding for the visually impaired people," in Proceedings of the 31st Annual International Conference of the IEEE Engineering in Medicine and Biology Society: Engineering the Future of Biomedicine (EMBC '09), pp. 7240–7243, IEEE, September 2009.
- [24] B.Hoyle, D.Withington, D.Waters, "UltraCane", Available from:"<http://www.soundforesight.co.uk/index.html>". June 2006.
- [25] E. Kee, "iSONIC cane for the virtually impaired", Available from:"<http://www.ubergizmo.com/2011/01/isonic-cane-for-the-virtuallyimpaired/>", 2011.
- [26] R.Farcy, R.Leroux, R.Damaschini, R.Legras, Y.Bellik, C.Jacquet, J.Greene, P.Pardo, "Laser Telemetry to improve the mobility of blind people: report of the 6 month training course", ICOST 2003 1st International Conference On Smart homes and health Telematics" Independent living for persons with disabilities and elderly people, Paris, pp. 24-26, 2003.
- [27] Amit kumar, M. Manjunatha and J. Mukhopadhyay, "An Electronic Travel Aid for Navigation of Visually Impaired Person," Proceeding of the 3rd International Conference on Communication Systems and Networks, pp.1-5, 2011.
- [28] <https://www.azosensors.com/article.aspx?ArticleID=225>
- [29] <http://osoyoo.com/2017/09/27/arduino-lesson-water-sensor/>
- [30] Direct mode ISD 1932. (2009, January 5) [Online]. https://www.futurashop.it/...PDF_ENG/7300ISD1932.pdf
- [31] http://www.trimble.com/gps_tutorial/gpswork-loc.aspx
- [32] <https://www.techopedia.com/definition/5062/global-system-for-mobile-communications-gsm>